

(12) **United States Patent**
Mohan et al.

(10) **Patent No.:** **US 10,375,798 B2**
(45) **Date of Patent:** **Aug. 6, 2019**

(54) **SELF-DETERMINING A CONFIGURATION OF A LIGHT FIXTURE**

(71) Applicant: **enLighted, Inc.**, Sunnyvale, CA (US)

(72) Inventors: **Tanuj Mohan**, Mountain View, CA (US); **Michael N. Gershowitz**, San Jose, CA (US); **Gaile Gordon**, Palo Alto, CA (US)

(73) Assignee: **Enlighted, Inc.**, Sunnyvale, CA (US)

(*) Notice: Subject to any disclaimer, the term of this patent is extended or adjusted under 35 U.S.C. 154(b) by 366 days.

(21) Appl. No.: **15/334,470**

(22) Filed: **Oct. 26, 2016**

(65) **Prior Publication Data**
US 2018/0116033 A1 Apr. 26, 2018

(51) **Int. Cl.**
G01J 1/42 (2006.01)
G01R 31/44 (2006.01)
H05B 37/02 (2006.01)

(52) **U.S. Cl.**
CPC **H05B 37/0227** (2013.01); **G01J 1/4204** (2013.01); **G01R 31/44** (2013.01); **H05B 37/0218** (2013.01); **H05B 37/0272** (2013.01); **Y02B 20/46** (2013.01)

(58) **Field of Classification Search**
CPC .. G01R 31/44; G01R 31/2635; G01R 31/025; G09G 3/006; G09G 3/3233
USPC 324/414
See application file for complete search history.

(56) **References Cited**

U.S. PATENT DOCUMENTS

2,694,792 A *	11/1954	Kewley	H01K 3/305 29/705
5,101,141 A	3/1992	Warner et al.	
5,179,324 A	1/1993	Audbert	
5,191,265 A	3/1993	D'Aleo et al.	
5,283,516 A	2/1994	Lohoff	
5,812,422 A	9/1998	Lyons	
6,057,654 A	5/2000	Cousy et al.	
6,188,181 B1	2/2001	Sinha et al.	
6,342,994 B1	1/2002	Cousy et al.	
6,502,044 B1	12/2002	Lane et al.	
6,548,967 B1	4/2003	Dowling et al.	
6,577,136 B1	6/2003	Marques	
7,309,985 B2	12/2007	Eggers et al.	
7,348,736 B2	3/2008	Piepgas et al.	
7,437,596 B2	10/2008	McFarland	
7,382,271 B2	12/2008	McFarland	
7,550,931 B2	6/2009	Lys et al.	
7,566,137 B2	7/2009	Veskovic	
7,623,042 B2	11/2009	Huizenga	
7,792,956 B2	9/2010	Choong et al.	
7,812,543 B2	10/2010	Budike, Jr.	
7,925,384 B2	4/2011	Huizenga et al.	

(Continued)

Primary Examiner — Christopher P McAndrew

(57) **ABSTRACT**

An apparatuses, methods, and systems of determining a configuration of a lighting fixture are disclosed. One embodiment method includes setting a lighting control level of a first channel control line of the lighting fixture to a plurality of levels, setting a lighting control level of a second channel control line of the lighting fixture to a plurality of levels, sensing an amount of power dissipated by the lighting fixture, comparing the sensed amount of power dissipated for each of the plurality of levels, and determining a configuration of the lighting fixture based upon the comparing of the sensed amount of power for each of the plurality of lighting control levels for the first channel and the second channel.

16 Claims, 8 Drawing Sheets

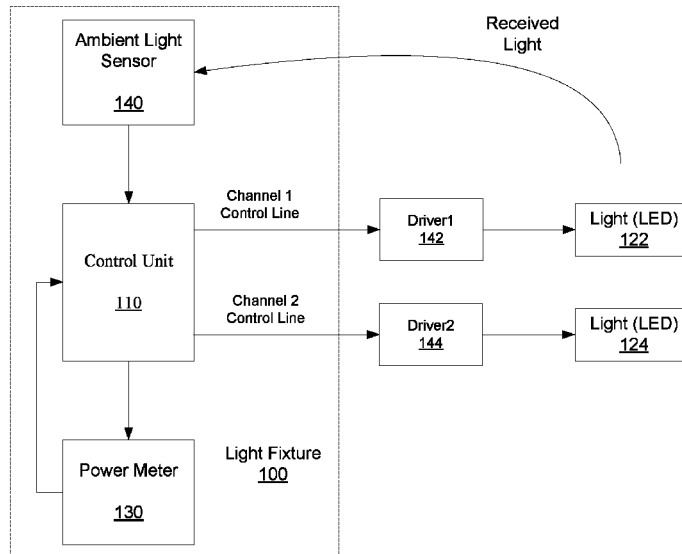

(56)

References Cited

U.S. PATENT DOCUMENTS

8,278,845	B1 *	10/2012	Woytowitz	H05B 37/0263 307/1	2010/0135186	A1	6/2010	Choong et al.
8,339,069	B2 *	12/2012	Chemel	H05B 37/029 315/294	2010/0264846	A1	10/2010	Chemal et al.
8,368,321	B2	2/2013	Chemel		2010/0270933	A1	10/2010	Chemal et al.
8,593,135	B2 *	11/2013	Chemel	H05B 37/029 324/105	2010/0280677	A1	11/2010	Budike, Jr.
8,593,148	B2 *	11/2013	Morrow	G01R 31/26 324/414	2010/0295482	A1	11/2010	Chemal et al.
8,610,377	B2 *	12/2013	Chemel	H05B 37/029 315/297	2010/0301777	A1	12/2010	Chemal et al.
8,705,023	B2 *	4/2014	Hong	G01J 1/0223 356/213	2011/0031897	A1	2/2011	Henig et al.
9,006,996	B2	4/2015	Mohan et al.		2011/0187273	A1 *	8/2011	Summerford
9,277,632	B2	3/2016	Hegarty					H05B 37/02 315/152
9,413,174	B2 *	8/2016	Gostein	H02S 50/10 324/414	2011/0199010	A1	8/2011	Henig et al.
2002/0084784	A1 *	7/2002	Cook	G01R 31/245 324/414	2012/0265467	A1 *	10/2012	Chang
2004/0002792	A1	1/2004	Hoffknecht		2012/0320627	A1 *	12/2012	Araki
2004/0212321	A1 *	10/2004	Lys	H05B 33/0809 315/291	2014/0084811	A1 *	3/2014	Bender
2005/0169643	A1	8/2005	Franklin et al.		2014/0167771	A1 *	6/2014	Hsu
2006/0275040	A1	12/2006	Franklin		2014/0218039	A1 *	8/2014	Shen
2007/0057807	A1	3/2007	Walters et al.		2014/0232409	A1 *	8/2014	Keum
2007/0061050	A1	3/2007	Hoffknecht		2014/0235269	A1 *	8/2014	Ericsson
2007/0086128	A1	4/2007	Lane et al.		2014/0266217	A1 *	9/2014	Wang
2007/0152797	A1 *	7/2007	Chemel	H05B 33/0803 340/2.2	2015/0048835	A1 *	2/2015	Lee
2007/0189026	A1 *	8/2007	Chemel	H05B 37/029 362/458	2015/0123667	A1 *	5/2015	Solarz
2007/0215794	A1	9/2007	Cernasov et al.		2015/0160275	A1 *	6/2015	Goergen
2008/0185597	A1	8/2008	Veskovic et al.		2015/0160305	A1	6/2015	Ilyes et al.
2008/0244104	A1	10/2008	Clemente		2015/0379910	A1 *	12/2015	Nishinohara
2008/0265796	A1	10/2008	Null		2016/0178173	A1 *	6/2016	Yadav
2008/0284442	A1 *	11/2008	Notohamiprodjo	H05B 41/2828 324/414	2016/0212818	A1	7/2016	Hegarty
2009/0026966	A1	1/2009	Budde et al.		2016/0286628	A1 *	9/2016	Cho
2009/0179596	A1	7/2009	Willaert et al.		2017/0105269	A1 *	4/2017	Balasubramainian
2009/0195161	A1	8/2009	Lane et al.					H05B 37/02 H05B 37/02
2009/0278479	A1	11/2009	Platner et al.		2017/0231069	A1 *	8/2017	Winslett
2010/0034386	A1	2/2010	Choong et al.		2018/0129493	A1 *	5/2018	Deixler
					2018/0146533	A1 *	5/2018	Goodman

* cited by examiner

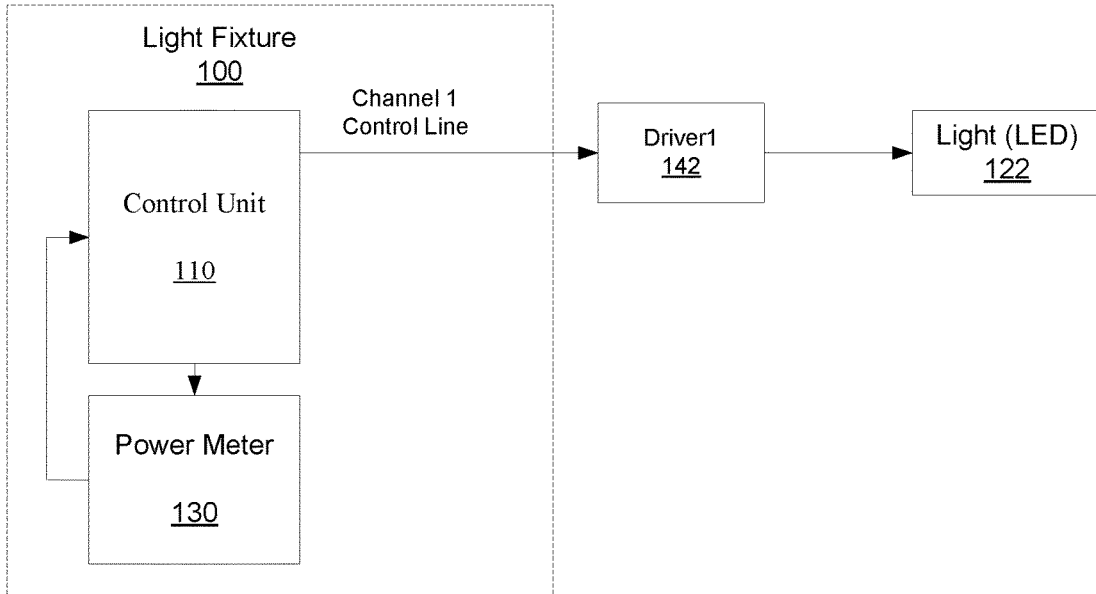

FIGURE 1A

Test	Dimming Control	Measured Power	AC Power Relay	Verification Test
1	N/A	E	OFF	E = a minimal level
2	100%	A	ON	A > min level power
3	20%	B	ON	B < 90% A: dimming control able to reduce load
4	0%	C	OFF	Light off
5	100%	D	ON	Light max brightness

FIGURE 1B

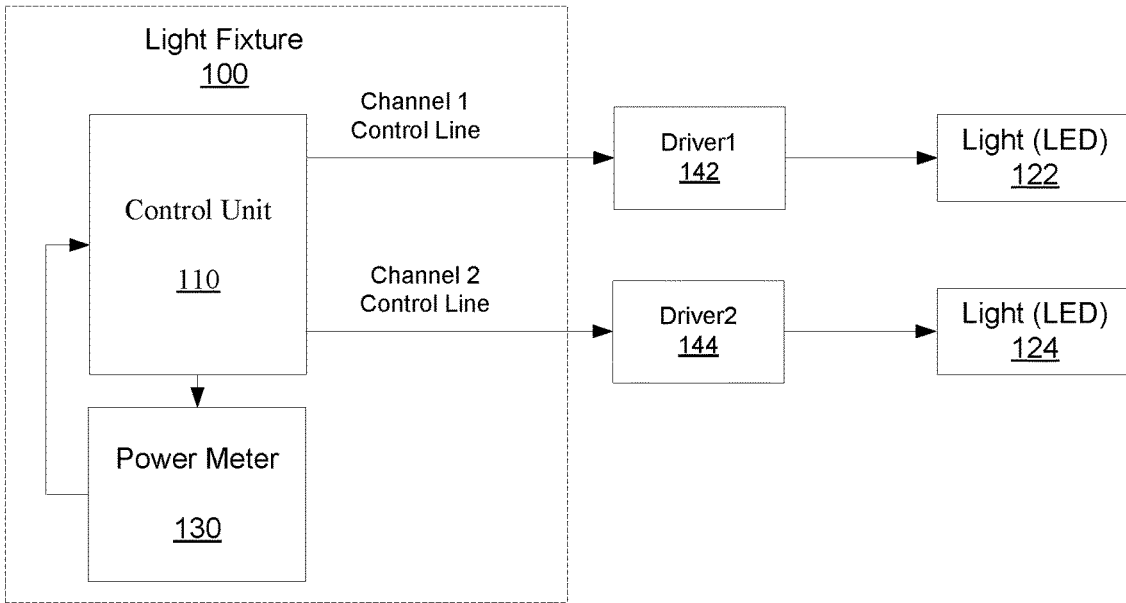

FIGURE 2A

Test	Dimming Control on Channel 1 and 2	Measured Power	AC Power Relay	Verification Test
1	1) N/A	E	OFF	$E > \text{min level threshold}$
2	1) 100% 2) 0%	A	ON	$A > \text{second threshold}$
3	1) 50% 2) 50%	B	ON	$B < 2/3A$ indicates 1 channel only, otherwise, a two channel fixture.
4	1) 100% 2) 100%	C	ON	$C > B$
5	1) 0% 2) 100%	D	ON	Channel 2 max brightness, $C * .2 < A + D < C * .8$ and $D < 2/3C$

FIGURE 2B

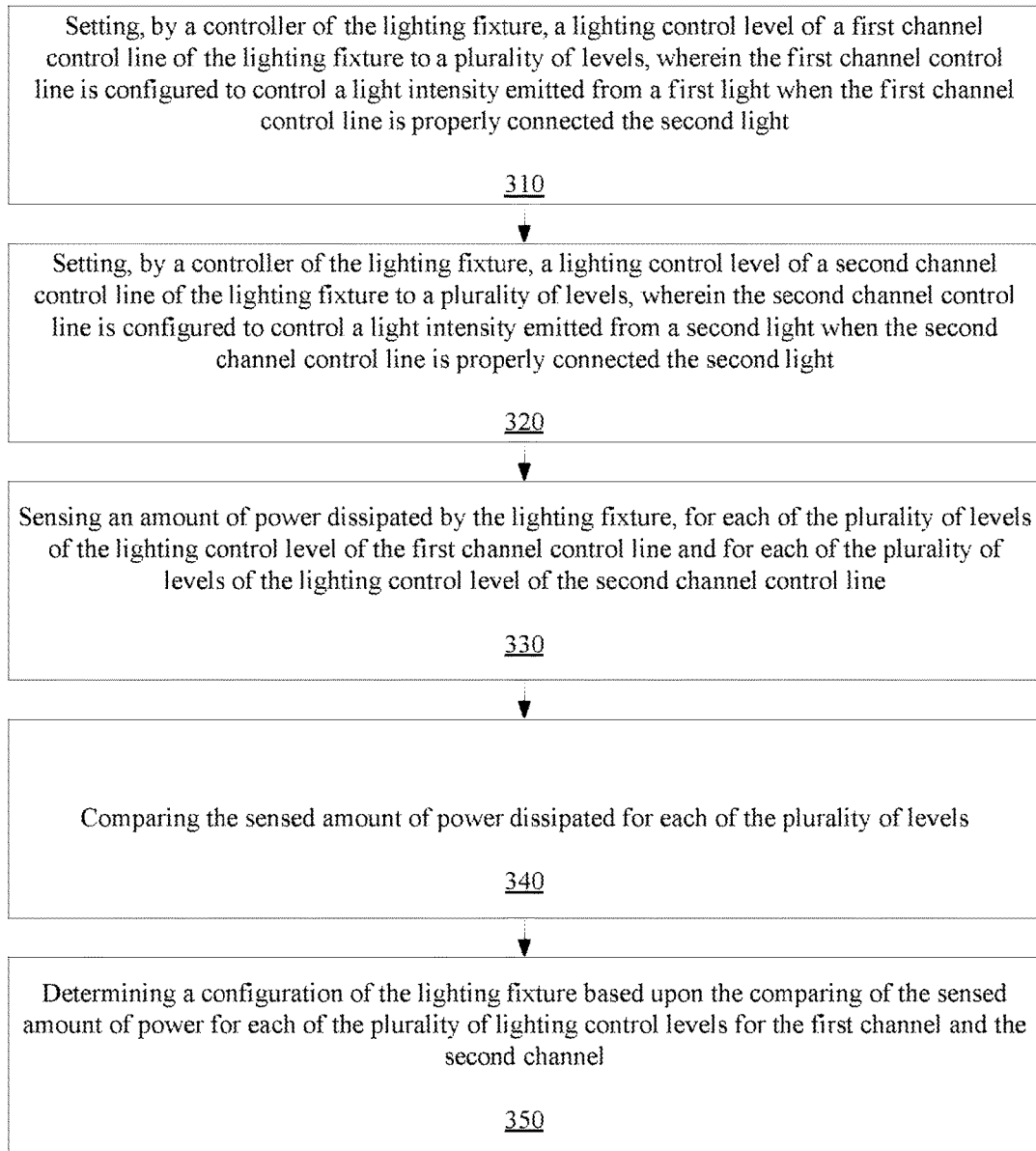

FIGURE 3

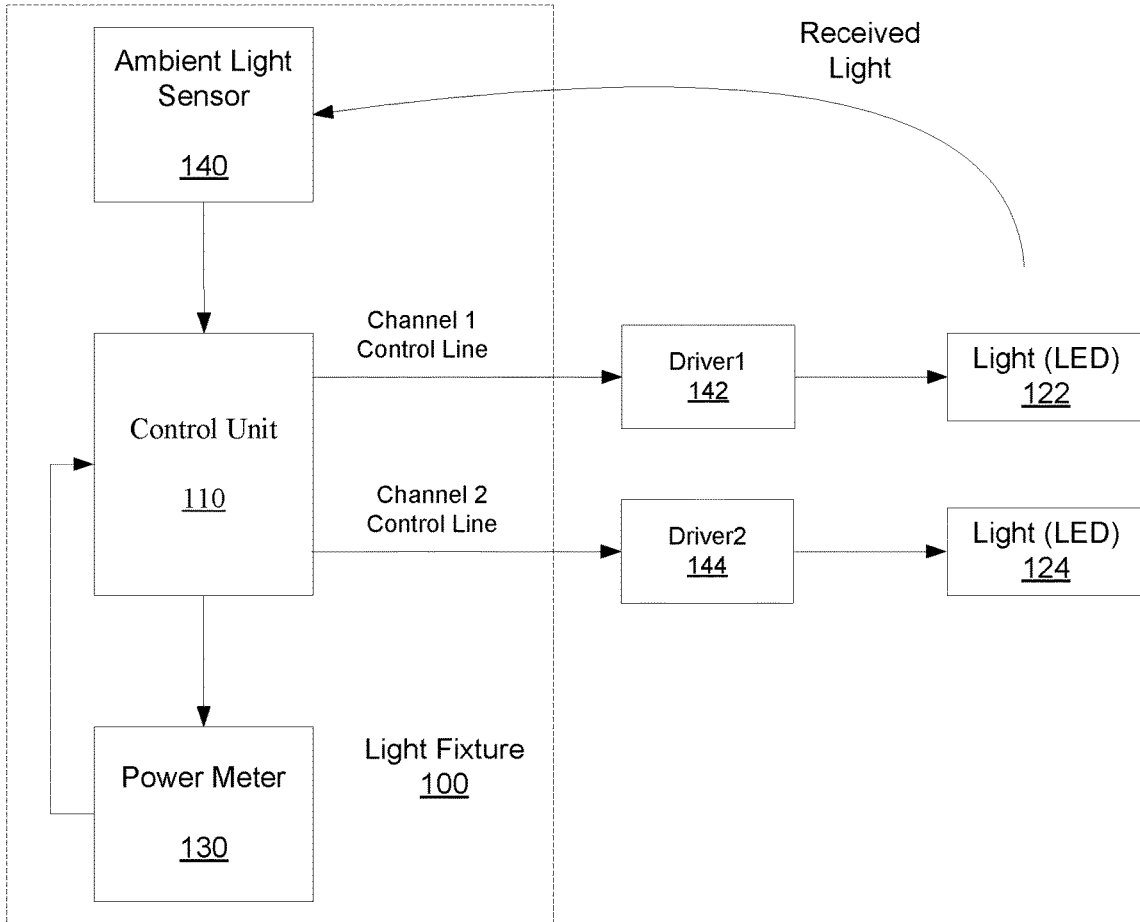

FIGURE 4A

Test	Dimming Control on Channel 1 and 2	Measured Power	Verification Test (Sensed Color of Light)
1	1) 100% 2) 0%	A	(RA, BA, GA)
2	1) 0% 2) 100%	D	(RD, BD, GD)

FIGURE 4B

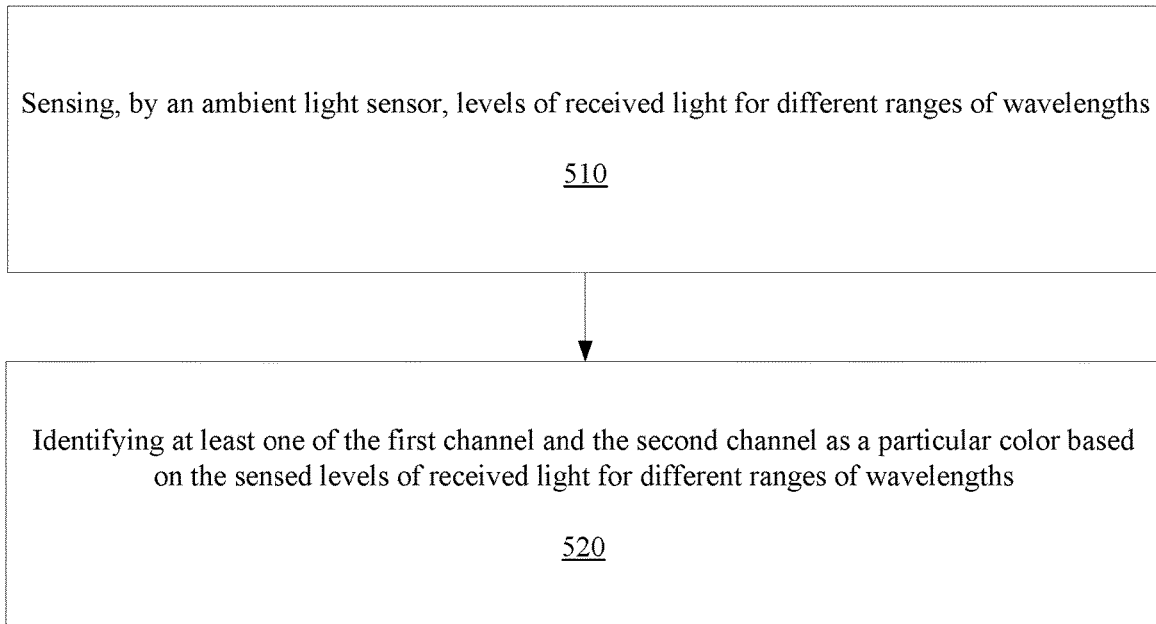

FIGURE 5

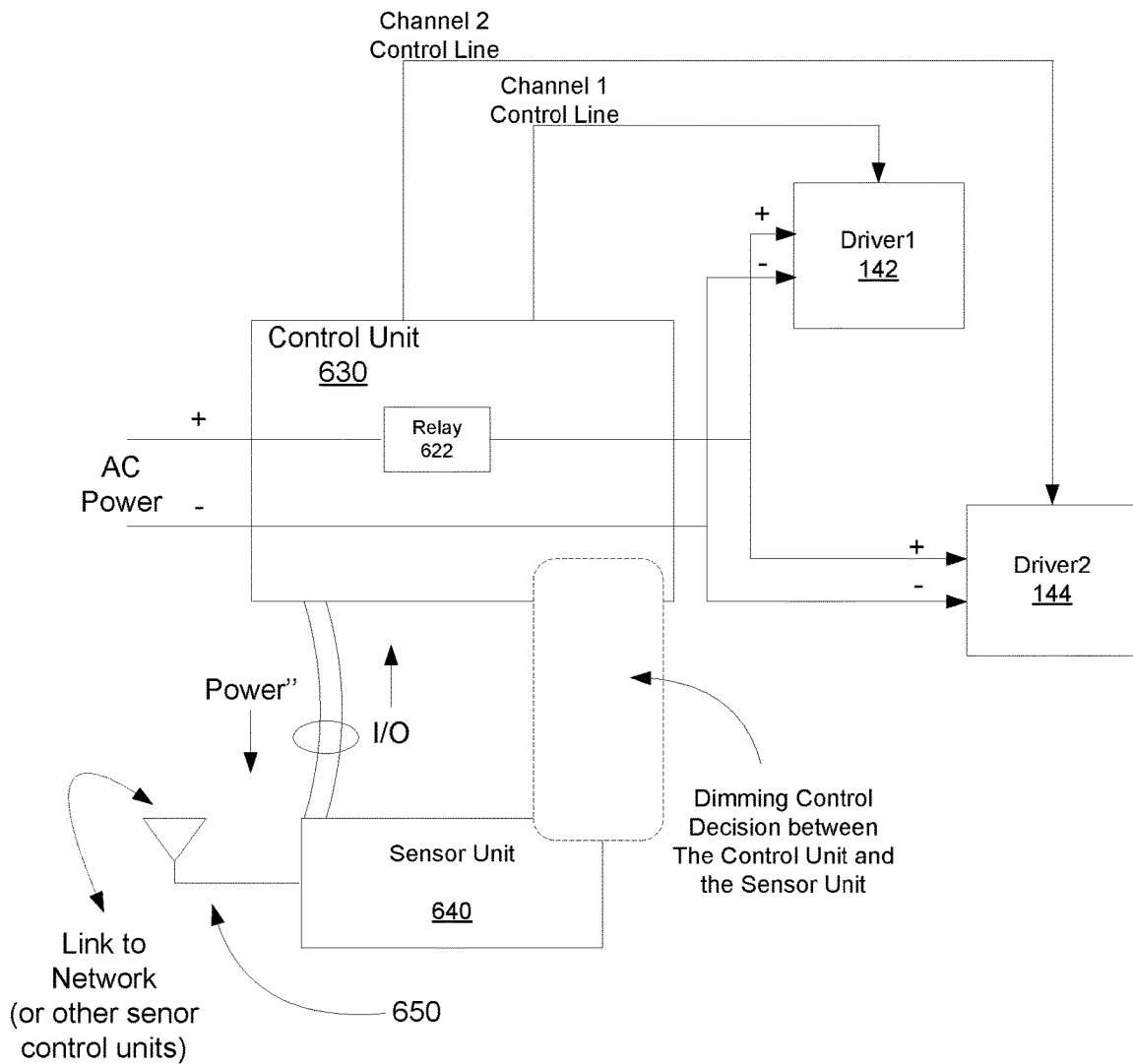

FIGURE 6

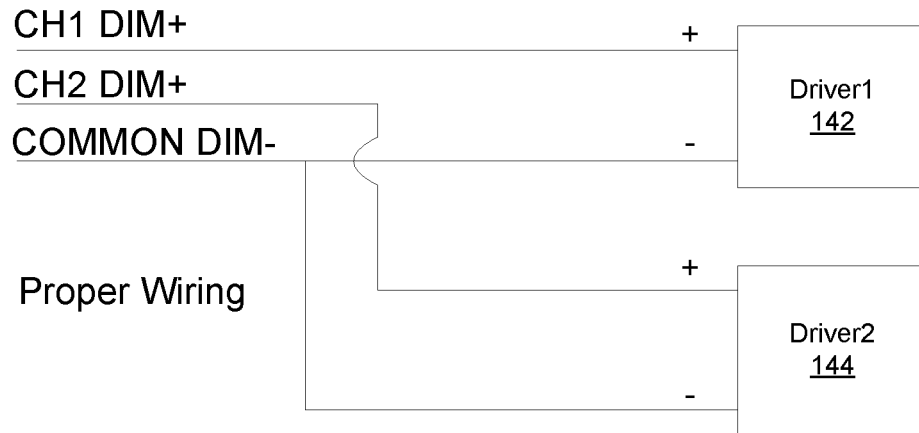

FIGURE 7A

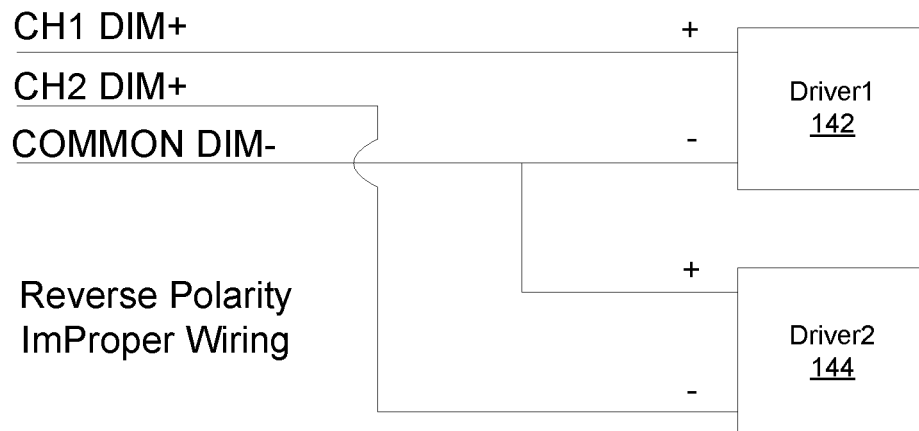

FIGURE 7B

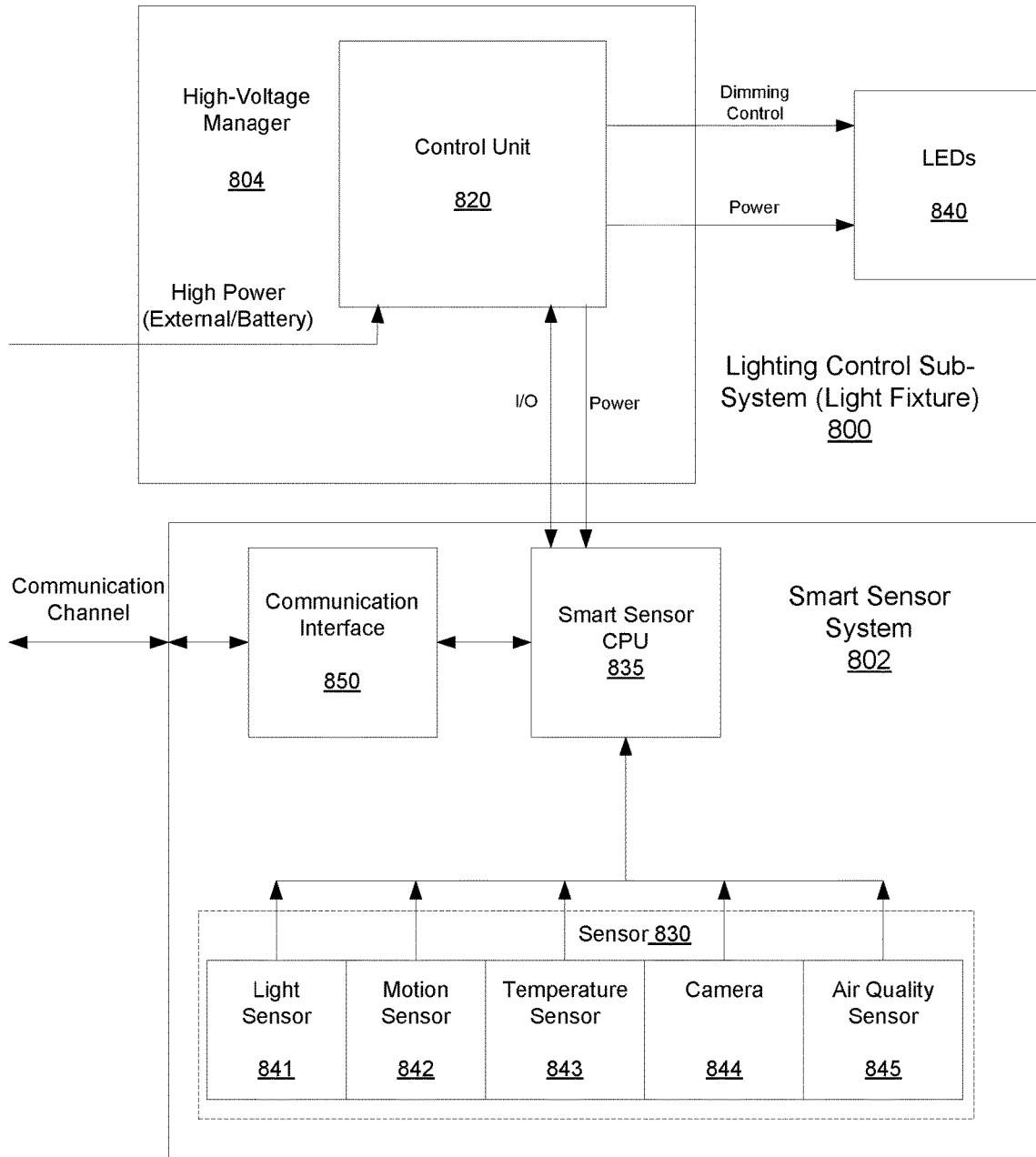

FIGURE 8

SELF-DETERMINING A CONFIGURATION OF A LIGHT FIXTURE

FIELD OF THE EMBODIMENTS

The described embodiments relate generally to lighting. More particularly, the described embodiments relate to self-determining a configuration of a light fixture.

BACKGROUND

Lighting control can be used to automatically control lighting under certain conditions, thereby conserving power. However, lighting control, specifically advanced lighting controls have not been widely adopted in the general commercial market because the installation, setup related costs and complexity have made these lighting systems prohibitively expensive for most commercial customers. Additionally, if these systems include intelligence, they are centrally controlled.

A common type of lighting fixture contains one LED (light emitting diode) channel which is controlled by a single channel dimming control. The dimming control can be analog, for instance a 0 to 10 v signal, or digital, for instance DALI (digital addressable lighting interface) or other control type. All the LEDs in the fixture are controlled by a single driver at the same dimming level. Some fixtures now have more than one LED channel or driver. Dual channels can be used to control for instance two long linear units to extend the size of the fixture, an indirect and direct light (up/down) lights in the same fixture, or two different color temperature LEDs. To control the fixture correctly, it must be known how many channels are present, and if there are two, which LED channel belongs to which control line.

It is desirable to have a lighting method, system and apparatus for self-configuration and testing of a lighting fixture that includes more than one channel.

SUMMARY

One embodiment includes a method of determining a configuration of a lighting fixture. The method includes setting, by a controller of the lighting fixture, a lighting control level of a first channel control line of the lighting fixture to a plurality of levels, wherein the first channel control line is configured to control a light intensity emitted from a first light when the first channel control line is properly connected the first light, setting, by the controller of the lighting fixture, a lighting control level of a second channel control line of the lighting fixture to a plurality of levels, wherein the second channel control line is configured to control a light intensity emitted from a second light when the second channel control line is properly connected the second light, sensing an amount of power dissipated by the lighting fixture, for each of the plurality of levels of the lighting control level of the first channel control line and for each of the plurality of levels of the lighting control level of the second channel control line, comparing the sensed amount of power dissipated for each of the plurality of levels, and determining a configuration of the lighting fixture based upon the comparing of the sensed amount of power for each of the plurality of lighting control levels for the first channel and the second channel.

Another embodiment includes lighting fixture. The lighting fixture includes a first channel control line configured to control a light intensity emitted from a first light of the lighting fixture when properly connected, a second channel

configured to control a light intensity emitted from a second light of the lighting fixture when properly connected, a power meter configured to sense power dissipated by the light fixture, and a controller. For an embodiment, the controller is configured to set a lighting control level of the first channel control line of the lighting fixture to a plurality of levels, set a lighting control level of the second channel control line of the lighting fixture to a plurality of levels, receive from the power meter a sensed amount of power dissipated by the lighting fixture, for each of the plurality of levels of the lighting control level of the first channel control line and for each of the plurality of levels of the lighting control level of the second channel control line, compare the sensed amount of power dissipated for each of the plurality of levels, and determine a configuration of the lighting fixture based upon the comparing of the sensed amount of power for each of the plurality of lighting control levels for the first channel control line and the second channel control line.

Other aspects and advantages of the described embodiments will become apparent from the following detailed description, taken in conjunction with the accompanying drawings, illustrating by way of example the principles of the described embodiments.

BRIEF DESCRIPTION OF THE DRAWINGS

FIG. 1A shows a light fixture that includes a control unit, a power meter, and a single channel, according to an embodiment.

FIG. 1B is a table that includes a series of tests for the single channel system of FIG. 1A, according to an embodiment.

FIG. 2A shows a light fixture that includes a control unit, a power meter, and multiple channels, according to an embodiment.

FIG. 2B is a table that includes a series of tests for the dual channel system of FIG. 2A, according to an embodiment.

FIG. 3 is a flow chart that includes steps of a method of controlling the light fixture of FIG. 1, according to an embodiment.

FIG. 4A shows a light fixture that includes a control unit, a power meter, an ambient light sensor, and multiple channels, according to an embodiment.

FIG. 4B is a table that includes dimming control of the two channels, measured power, and sensed colors of light for the light fixture of FIG. 4A, according to an embodiment.

FIG. 5 is a flow chart that includes steps of a method of controlling the light fixture of FIG. 3, according to an embodiment.

FIG. 6 shows another light fixture, according to an embodiment.

FIGS. 7A and 7B show examples of proper and improper wiring between the control unit and the drivers, according to an embodiment.

FIG. 8 shows another light fixture, according to an embodiment.

DETAILED DESCRIPTION

The described embodiments are embodied in apparatuses, system and methods for automatically self-determining a configuration of a light fixture. Further, at least some of the described embodiments include automatic testing for correct wiring of the light fixture at manufacturing or installation. At least some embodiments include a common test for a wide variety of different fixtures—so that changes are not

required to existing manufacturing flow, and so that the same software and/or firmware can be used without having to know a detailed configuration of the light fixture.

FIG. 1A shows a light fixture **100** that includes a control unit **110**, a power meter **130**, and a single channel, according to an embodiment. The control unit **110** controls the generation of a channel 1 control line which controls a first driver (Driver1) **142**. The first driver **142** controls an intensity of light emitted from a light **122**. For an embodiment, the light **122** is an LED (light emitting diode).

The power meter **110** senses power dissipated by the light fixture **100**. The various controls and operations of the light fixture **100** cause the light fixture **100** to consume or dissipate different levels of power. For example, if properly connected, setting the signal level of the first driver control line to different levels causes different levels of dissipated power by the light fixture.

FIG. 1B is a table that includes a series of tests for the single channel system of FIG. 1A, according to an embodiment. For an embodiment, a test (test 1 of table 1) for a single channel fixture includes providing a sequence of dimming levels, power relay settings, and measuring power at each level. According to an embodiment, a first test verifies the power wiring between the control unit **110** and the Driver **142**. An AC power test is realized, for example, by closing or opening a relay **622** of FIG. 6 as will be described later. The relay **622** either provides power (closed) to the driver **142**, or provides for no power (open) to the driver **142**. The power meter **130** may sense a level of power dissipation of the light fixture **100** of E.

For an embodiment, a second test (Test 2 from table 1) includes controlling the light fixture **100** with the brightest dimming control (100%, wherein 100% indicates 100% of the maximum brightness setting). If the power measured, A, is above some reasonable minimum detectable level, this shows there is a load correctly connected to the driver **143**. In a typical system, power measured with no load would indicate a very low value (the power consumption of the sensor alone), whereas even the smallest LED unit at full dimming level will read a much higher level of power consumption.

The third test (Test 3 of table 1) includes reducing the dimming control, for example, to 20%, wherein 20% indicates 20% of the maximum brightness setting. The power measured at this point, B, is expected to be lower than A. Even with rough calibration of the dimming, and to allow for different drivers, if B is lower than 90% of A, there is strong evidence that the dimming is functional to lower the brightness of the light.

A fourth test (test 4 of table 1) includes driving the light fixture at the minimum dimming control value (0%). The light **122** should be visibly confirmed by an operator or installer to be at the minimum brightness. The power meter **130** may sense a level of power dissipation of the light fixture **100** of C.

A fifth test (test 5 of table 1) includes driving the fixtures at 100% dimming control to verify full brightness of the fixture. The power meter **130** may sense a level of power dissipation of the light fixture **100** of D. The last two tests (4 and 5) are used to identify that the LED unit is functional.

An ambient light sensor could optionally be used in tests 4 and 5. Ambient light sensed will be a combination of the light from the fixture and other light in the area, for instance from a window or other fixtures. If these conditions can be controlled, for instance in a manufacturing facility, the ambient sensor can be used instead of the visible test to fully automate the tests.

FIG. 2A shows a light fixture **100** that includes the control unit **110**, the power meter **130**, and multiple channels (Channel 1, Channel 2), according to an embodiment. This embodiment further includes a channel 2 control line which controls a second driver (Driver2) **144** which controls the intensity of light emitted from a second light **124**. For an embodiment, the light **124** is an LED (light emitting diode).

For an embodiment, the light fixture **100** is operative to self-determine the configuration the light fixture. That is, the light fixture **100** may be configured as a single channel fixture as shown in FIG. 1A, or the light fixture **100** may be configured as a dual channel fixture as shown in FIG. 2A. For an embodiment, the configuration can be determined by the control unit varying control of the channel 1 control line and the channel 2 control line, and monitoring the power dissipated by the light fixture while varying control of the channel 1 control line and the channel 2 control line.

It is to be realized that while the describe embodiments only include one or two channels, the described embodiments can be extended to any number of channel drivers

When the control unit is determining whether it controls a single or dual channel fixture, the complexity of the test of the configuration is greater. For an embodiment, a test for a dual channel light fixture includes providing a sequence of dimming levels, power relay settings, and measuring power at each level.

FIG. 2B is a table that includes a series of tests for the dual channel system of FIG. 2A, according to an embodiment. A first test (test 1 table 2) verifies the power wiring between the control unit **110** and the Drivers **142**, **144**. The AC Power Relay (as depicted by the relay **622** in FIG. 6) is turned off (dimming controls not applicable in this state). In this state, the only power used is what is drawn by the sensor and control unit, which is minimal, but not zero. If the sensed power dissipation is zero, this indicates a power wiring error (the control unit **110** is bypassed or mis-wired), or the control unit is defective. The power meter **130** may sense a level of power dissipation of the light fixture **100** of E.

An embodiment includes first identifying the number of channels of the light fixture. For at least some embodiments, this includes a two-step test. A first step (test 2 of table 2) of the two-step test includes verifying a minimum load on the channel 1 control line. The dimming control of channel 1 is set to 100% and the dimming control of channel 2 is set to 0%. The power measured in this configuration is A. If the power measured, A, is above some reasonable minimum detectable level (second threshold), this shows there is a load correctly connected to the driver **142**. In a typical system, power measured with no load would indicate a very low value (the power consumption of the sensor alone), whereas a even the smallest LED unit at full dimming level will read a higher power consumption.

The second test (test 3 table 2) controls the two channels (the channel 1 control line and the channel 2 control line) at equal 50% levels. Typically for a two channel configuration the power measured, B, is approximately the same as A, whereas a single channel configuration reads B much less than A. For an embodiment, for the one channel configuration, the testing includes a return to step 2 of the table of FIG. 1B.

For a detected dual channel configuration, the test continues with tests 4 and 5 of the table of FIG. 2B to verify dimming capability on both channels. Test 4 includes setting channel 1 to 100% and channel 2 to 100%, and the power meter measuring a power level of C. Test 5 includes setting channel 2 to 0% and channel 2 to 100%, and the power meter measuring a power level of D.

5

If correctly connected, then $A+D$ should be approximately equal to C . Again to allow for different configurations and drivers, a conservative test such as $C*0.2 < A+D < C*0.8$ may be used. D should also be much less than C , and the test can include determining that $D < 2/3 C$. The combination of these tests can be used to confirm the connections and drivers on each channel.

FIG. 3 is a flow chart that includes steps of a method of controlling the light fixture of FIG. 1B, according to an embodiment. A first step 310 includes setting, by a controller of the lighting fixture, a lighting control level of a first channel control line of the lighting fixture to a plurality of levels, wherein the first channel control line is configured to control a light intensity emitted from a first light when the first channel control line is properly connected the first light. A second step 320 includes setting, by the controller of the lighting fixture, a lighting control level of a second channel control line of the lighting fixture to a plurality of levels, wherein the second channel control line is configured to control a light intensity emitted from a second light when the second channel control line is properly connected the second light. A third step 330 includes sensing an amount of power dissipated by the lighting fixture, for each of the plurality of levels of the lighting control level of the first channel control line and for each of the plurality of levels of the lighting control level of the second channel control line. A fourth step 340 includes comparing the sensed amount of power dissipated for each of the plurality of levels. A fifth step 350 includes determining a configuration of the lighting fixture based upon the comparing of the sensed amount of power for each of the plurality of lighting control levels for the first channel and the second channel. For an embodiment, determining the configuration of a lighting fixtures includes determining if the fixture is connect to one or more driver loads For an embodiment the steps of FIG. 3 are performed after verification of the power wiring. If power wiring error was present the power measurements would not be indicative of the correct fixture state.

For an embodiment, the first channel control line is configured to control the light intensity emitted from the first light comprise the first channel control line being connected to a first driver, and wherein the second channel control line is configured to control the light intensity emitted from the second light comprise the second channel control line being connected to a second driver.

For an embodiment, setting the lighting control level of the first channel control line of the lighting fixture to the plurality of levels and setting the lighting control level of the second channel comprises at least setting the lighting control of the first channel control line to approximately 100% and the lighting control of the second channel control line to approximately 0%, and further comprising sensing a first sensed power level of the fixture, and confirming that the first sensed power level is greater than a first predetermined threshold. For an embodiment these steps are an implementation of test 2 of the table of FIG. 2B.

For an embodiment, setting the lighting control level of the first channel control line control line of the lighting fixture to the plurality of levels and setting the lighting control level of the second channel control line comprises at least setting the lighting control of the first channel to approximately 50% and the lighting control of the second channel control line to approximately 50%, and further comprising sensing a second sensed power level of the fixture, and determining that the lighting fixture is a single channel lighting fixture if the second sense power level is less than a predetermined ratio (for an embodiment, the

6

predetermine ratio is $2/3$) of the first sensed power level, and determining the lighting fixture is a dual channel lighting fixture if the second sensed power level is more than predetermined ratio (as stated, for an embodiment, the predetermine ratio is $2/3$) of the first sensed power level. For an embodiment these steps are an implementation of test 3 of the table of FIG. 2B.

For an embodiment, setting the lighting control level of the first channel control line of the lighting fixture to the plurality of levels and setting the lighting control level of the second channel control line comprises at least setting the lighting control of the first channel control line to approximately 100% and the lighting control of the second channel control line to approximately 100%, and further comprising sensing a third sensed power level of the fixture, and determining that the first channel control line and the second channel control line are properly connected and drivers are operable if the third sensed power level is greater than the first sensed power level and the second sensed power level. A visual test that each light is at maximum brightness level confirms that the fixture is properly operating. For an embodiment these steps are an implementation of test 4 of the table of FIG. 2B.

For an embodiment, setting the lighting control level of the first channel control line of the lighting fixture to the plurality of levels and setting the lighting control level of the second channel control line comprises at least setting the lighting control of the first channel control line to approximately 0% and the lighting control of the second channel control line to approximately 100%, and further comprising sensing a third sensed power level of the fixture, and determining that the first channel control line and the second channel control line are properly connected and drivers are operable if a second predetermined ratio (for an embodiment, the second predetermine ratio is 0.2) of the third sensed power level is less than a sum of the first sensed power level and the second sensed power level, and the sum of the first sensed power level and the second sensed power level is less than a third predetermine ratio (for an embodiment, the third predetermine ratio is 0.8) of the third sensed power level, and the fourth sensed power level is less than a fourth predetermine ratio (for an embodiment, the fourth predetermine ratio is $2/3$) of the third sensed power level. For an embodiment this test confirms that both dimming channels and corresponding drivers and lights are operational. For an embodiment these steps are an implementation of test 5 of the table of FIG. 2B.

FIG. 4A shows a light fixture that includes a control unit 110, a power meter 130, an ambient light sensor 140, and multiple channels (Channel 1 control line, Channel 2 control line, Driver1 142, Driver2 144), according to an embodiment. As shown, the ambient light sensor 140 is configured to receive light from the light 122 controlled by the Channel 1 control line and the light 124 controlled by the Channel 2 control line.

FIG. 4B is a table that includes dimming control of the two channels, measured power, and sensed colors of light for the light fixture of FIG. 4A, according to an embodiment. A first test includes setting the first channel to 100% and the second channel to 0%. The second test includes setting the first channel to 0% and the second channel to 100%. The power meter 130 sensed power levels of A and D for the two tests. The previously described power tests cannot determine if the two channels represent a tunable white configuration with different LED colors on each channel. For at least some embodiments, tunable white configurations use one cool white LED, for instance 6000 CCT (correlated color tem-

perature) and one warm white LED, for instance 2700 CCT. The total output of the fixture is blended using a diffuser to reach any combination of the two CCT colors. Use of an RGB ambient sensor on the fixture can confirm, using test 1 and 2 of the table of FIG. 4B whether there is a significant difference of red/blue. At least some embodiments include confirmation or automatic configuration of which channel is connected to the warm LED and which channel is connected to the cool LED. Warm CCT colors have a higher red and lower blue wavelengths compared to cool CCT colors.

Again referring to the table of FIG. 4B, RA is a sensed level of red light, BA is a sensed level of blue light, and GA is a sensed level of green light for test 1; RD is a sensed level of red light, BD is a sensed level of blue light, and GD is a sensed level of green light for test 2. For an embodiment, if $(RA/BA) << (RD/BD)$ then channel 1 is cool and channel 2 is warm. For an embodiment, if $(RA/BA) >> (RD/BD)$ → channel 2 is cool and channel 1 is warm. Otherwise, if the ratios are similar in test 1 and 2, the light fixture is not a tunable white fixture.

At least some embodiments include some control over the ambient environment of the fixture is required. For instance, if the ambient light not from the fixture (either channel 1 or 2) is extremely bright, there may not be a detectable difference measured when the fixture is configured on full brightness on either channel. The total ambient light measurement in either case 1 or 2, must be confirmed to be higher in magnitude than the total ambient light measurement with the fixture power off.

FIG. 5 is a flow chart that includes steps of a method of controlling the light fixture of FIG. 4A, according to an embodiment. A first step 510 includes sensing, by an ambient light sensor, levels of received light for different ranges of wavelengths. A second step 520 includes identifying at least one of the first channel and the second channel as a particular color based on the sensed levels of received light for different ranges of wavelengths.

For at least some embodiments, the sensing, by the ambient light sensor, is performed after determining the light fixture is in a controlled environment. For example, performing the sensing while the light fixture is in the dark allows for more accurate sensing of the ambient light of the lights 122, 124 because when the light fixture is in the dark other sources of ambient light are minimized. Accordingly, an embodiment includes timing the sensing of ambient light to occur at a time in which other sources of ambient light around the light fixture are controlled, such as, at night.

An embodiment includes identifying at least one of the first channel and the second channel as a warm light based on the sensed levels of received light for different ranges of wavelengths. For an embodiment, identifying at least one of the first channel and the second channel as a warm light comprises determining a ratio of sensed red light to sensed blue light.

An embodiment includes identifying at least one of the first channel and the second channel as a cool light based on the sensed levels of received light for different ranges of wavelengths. For an embodiment, identifying at least one of the first channel and the second channel as a cool light comprises determining a ratio of sensed red light to sensed blue light.

FIG. 6 shows another light fixture, according to an embodiment. This embodiment includes the previously described relay 622. The relay 622 receives AC power and, as previously described, the relay 622 either provides power (closed) to the drivers 142, 144, or provides for no power (open) to the drivers 142, 144. As shown, for an embodi-

ment, the relay 622 is included within the control unit 630. As previously described, if properly connected, the control unit 622 controls the light intensity of the lights 122, 144 through the channel control lines (Channel 1 Control Line, Channel 2 Control Line) through the drivers (Driver1 142, Driver2, 144).

For an embodiment, the relay 622 is turned off (dimming controls not applicable in this state). In this state, the only power used is what is drawn by the sensor and CU, which is minimal, but not zero. If the sensed power dissipation is zero, this indicates a power wiring error (the CU power meter 130 is bypassed or mis-wired, or the CU 630 is defective).

For an embodiment, the control unit 630 provides power to a sensor unit 640, and the sensor unit 640 provides at least some digital control of the control unit 630. Further, for at least some embodiments, the sensor unit 640 includes a wireless interface (including antenna 650) that provides a communication channel for the light fixture, thereby connecting the light fixture to other fixtures or a central controller. As shown, the dimming control decisions and processing can be shared between the control unit 630 and the sensor unit 640.

FIGS. 7A and 7B show examples of proper and improper wiring between the control unit and the drivers, according to an embodiment. FIG. 7A shows the wiring in which the dimming control line (CH1 DIM+) is properly connected to the Driver1 142, and the dimming control line (CH2 DIM+) is properly connected to the Driver2 144. Further, the common voltage line (COMMON DIM-) is properly connected to the Driver1 142 and the Driver2 144.

FIG. 7B shows a potential problem with the connection in which the dimming control line (CH2 DIM+) and the common voltage line (COMMON DIM-) are inadvertently reversed.

FIG. 8 shows another light fixture 800, according to an embodiment. More specifically, Control Unit 820 is connected to a LEDs 840, and provides a dimming control and power for controlling the intensity of light emitted from the LEDs 840. Note that the drivers are not depicted in this embodiment. Additionally, a sensor unit 802 is connected to the Control Unit 820. The control unit 820 can be located within a high-voltage manager 804 that receives power which is distributed to the control unit 820 and a smart sensor system 802.

For an embodiment, the Control Unit 820 (of the high-voltage manager 804) provides power to the smart sensor system 802, which includes smart sensor CPU 835, and the smart sensor CPU 835 provides control signals to the Control Unit 820. This embodiment further includes a communications link being established between the smart sensor system 802 and a network or other devices. Rather than being connected to the network, the sensor unit smart sensor system 802 includes a communication interface 850 that can connect to other sensor units and Control Units, allowing for decentralized control of a plurality of light fixtures. For a specific embodiment, the sensor unit 802 includes at least one antenna and is wirelessly linked (through, for example, BLUETOOTH® or ZIGBEE®) to the network, or other devices.

For an embodiment, the conductor providing power from the high-voltage manager 804 to the smart sensor system 802, and the conductor(s) providing control signal(s) from the smart sensor system 802 to the high-voltage manager 804 are located in a common cable. For an embodiment, the voltage providing to power the smart sensor system 802 is, for example, a low-power DC voltage. Being a low voltage,

the smart sensor system **802** can be connected, and re-connected to the high-voltage manager **804** by a lay-person (that is, a skilled, high-cost technician is not required for deploying the LED lighting system). That is, the voltage supply is low enough that, for example, replacement of the sensor unit is safe enough that an electrician is not required to make the replacement.

For an embodiment, the smart sensor system **802** is attached to a ceiling proximate to the high-voltage manager **804**. The cable allows for easy installation. Exemplary cables include a cable with a RJ-45, RJ-50 like connector at either end. Flat cables can be desirable because that can easily slip easily between a guide-rail and a ceiling tile of a typical industrial ceiling, without requiring a hole in a ceiling tile.

Embodiments include all of the LED processing based on the sensed signals and any network input occurring all or partially within the sensor system **802**. Other embodiments include varying amount of the driver control processing occurring within the Control Unit **820** of the high-voltage manager **804**. The dimming control decisions can be distributed between the Control Unit **820** and the sensor unit CPU **835**.

An existing light fixture can be upgraded as shown without having to modify or update existing electrical wiring and switches. This is very desirable because the upgrade is easy, fast and inexpensive to implement. Once upgraded, many light fixtures can be managed with decentralized control. Decentralized control is desirable over centralized control because there is not a single point of failure. A purchaser of the retrofit kits can upgrade existing light fixtures over time.

The smart sensor system **802** includes sensors **830** (light or ambient light sensor **841**, motion sensor **842**, temperature sensor **843**, camera **844**, and/or air quality sensor **845**) that sense conditions that are used for controlling the intensity of light emitted from the LEDs **840**. Such sensed signals include at least one of motion, light, temperature, images, etc. It is to be understood that this is not an exhaustive list of possible sensed conditions.

Although specific embodiments have been described and illustrated, the described embodiments are not to be limited to the specific forms or arrangements of parts so described and illustrated. The embodiments are limited only by the appended claims.

What is claimed:

1. A method of determining a configuration of a lighting fixture, comprising:

setting, by a controller of the lighting fixture, a lighting control level of a first channel control line of the lighting fixture to a plurality of levels, wherein the first channel control line is configured to control a light intensity emitted from a first light when the first channel control line is properly connected the first light, and wherein the second channel control line is connected to a second driver;

setting, by the controller of the lighting fixture, a lighting control level of a second channel control line of the lighting fixture to a plurality of levels, wherein the second channel control line is configured to control a light intensity emitted from a second light when the second channel control line is properly connected the second light, and wherein the first channel control line is connected to a first driver;

sensing an amount of power dissipated by the lighting fixture, for each of the plurality of levels of the lighting control level of the first channel control line and for

each of the plurality of levels of the lighting control level of the second channel control line;
 comparing to one another the sensed amount of power dissipated for each of the plurality of levels;
 determining a configuration of the lighting fixture based upon the comparing of the sensed amount of power for each of the plurality of lighting control levels for the first channel and the second channel,
 controlling opening and closing of a relay within the controller, wherein the relay is operative electrically connect electrical power to the first driver and the second driver;
 sensing an amount of power dissipated by the lighting fixture when the relay is open and closed; and
 determining whether the controller electrically connected properly based on a comparison of the sensed amount of power dissipated by the lighting fixture when the relay is open and closed.

2. The method of claim **1**, wherein setting the lighting control level of the first channel control line of the lighting fixture to the plurality of levels and setting the lighting control level of the second channel control line comprises at least setting the lighting control of the first channel control line to approximately 100% and the lighting control of the second channel control line to approximately 0%, and further comprising sensing a first sensed power level of the fixture, and confirming that the first sensed power level is greater than a first predetermined threshold.

3. The method of claim **2**, wherein setting the lighting control level of the first channel control line control line of the lighting fixture to the plurality of levels and setting the lighting control level of the second channel control line comprises at least setting the lighting control of the first channel to approximately 50% and the lighting control of the second channel control line to approximately 50%, and further comprising sensing a second sensed power level of the fixture, and determining that the lighting fixture is a single channel lighting fixture if the second sense power level is less than a predetermined ratio of the first sensed power level, and determining the lighting fixture is a dual channel lighting fixture if the second sensed power level is greater than the predetermined ratio of the first sensed power level.

4. The method of claim **3**, wherein setting the lighting control level of the first channel control line of the lighting fixture to the plurality of levels and setting the lighting control level of the second channel control line comprises at least setting the lighting control of the first channel control line to approximately 100% and the lighting control of the second channel control line to approximately 100%, and further comprising sensing a third sensed power level of the fixture, and determining that the first channel control line and the second channel control line are properly connected if the third sensed power level is greater than the first sensed power level and the second sensed power level.

5. The method of claim **4**, wherein setting the lighting control level of the first channel control line of the lighting fixture to the plurality of levels and setting the lighting control level of the second channel control line comprises at least setting the lighting control of the first channel control line to approximately 0% and the lighting control of the second channel control line to approximately 100%, and further comprising sensing a third sensed power level of the fixture, and determining that the first channel control line and the second channel control line are properly connected if a second predetermine ratio of the third sensed power level is less than a sum of the first sensed power level and the

11

second sensed power level, and the sum of the first sensed power level and the second sensed power level is less than a third predetermine ratio of the third sensed power level, and the fourth sensed power level is less than a fourth predetermine ration of the third sensed power level.

6. The method of claim 1, further comprising:

measuring an intensity of light emitted from the first light and the second light for each of the plurality of levels of the lighting control level of the first channel control line and for each of the plurality of levels of the lighting control level of the second channel control line;

comparing the measuring the intensity of light for each of the plurality of levels; and

further determining the configuration of the lighting fixture based upon the measuring of the intensity of light for each of the plurality of levels for the first channel control line and the second channel control line.

7. The method of claim 1, further comprising:

sensing, by an ambient light sensor, levels of received light for different ranges of wavelengths.

8. The method of claim 7, wherein the sensing, by the ambient light sensor, is performed after determining the light fixture is in a controlled environment.

9. The method of claim 7, identifying at least one of the first channel and the second channel as a particular color based on the sensed levels of received light for different ranges of wavelengths.

10. The method of claim 9, identifying at least one of the first channel and the second channel as a warm light based on the sensed levels of received light for different ranges of wavelengths.

11. The method of claim 10, wherein identifying at least one of the first channel and the second channel as a warm light comprises determining a ratio of sensed red light to sensed blue light.

12. The method of claim 9, identifying at least one of the first channel and the second channel as a cool light based on the sensed levels of received light for different ranges of wavelengths.

13. The method of claim 12, wherein identifying at least one of the first channel and the second channel as a cool light comprises determining a ratio of sensed red light to sensed blue light.

14. A lighting fixture, comprising:

a first channel control line configured to control a light intensity emitted from a first light of the lighting fixture when properly connected, wherein the first channel control line is connected to a first driver;

a second channel configured to control a light intensity emitted from a second light of the lighting fixture when properly connected, wherein the second channel control line being is connected to a second driver;

12

a power meter configured to sense power dissipated by the light fixture;

a controller including a relay, wherein the relay is configured to electrically connect electrical power to the first driver and the second driver, the controller configured to:

set a lighting control level of the first channel control line of the lighting fixture to a plurality of levels;

set a lighting control level of the second channel control line of the lighting fixture to a plurality of levels;

receive from the power meter a sensed amount of power dissipated by the lighting fixture, for each of the plurality of levels of the lighting control level of the first channel control line and for each of the plurality of levels of the lighting control level of the second channel control line;

compare to one another the sensed amount of power dissipated for each of the plurality of levels;

determine a configuration of the lighting fixture based upon the comparing of the sensed amount of power for each of the plurality of lighting control levels for the first channel control line and the second channel control line;

control opening and closing of the relay, wherein the relay is operative electrically connect electrical power to the first driver and the second driver;

receive a sensed an amount of power dissipated by the lighting fixture when the relay is open and closed from the power meter; and

determine whether the controller electrically connected properly based on a comparison of the sensed amount of power dissipated by the lighting fixture when the relay is open and closed.

15. The light fixture of claim 14, further comprising:

an ambient light sensor configured to measure an intensity of light emitted from the first light and the second light for each of the plurality of levels of the lighting control level of the first channel control line and for each of the plurality of levels of the lighting control level of the second channel control line;

wherein the controller is operative to:

compare the measuring the intensity of light for each of the plurality of levels; and

determine the configuration of the lighting fixture based upon the measuring of the intensity of light for each of the plurality of levels for the first channel control line and the second channel control line.

16. The light fixture of claim 14, further comprising:

an ambient light sensor operative to sense levels of received light for different ranges of wavelengths.

* * * * *